

MultiSurface Worktop Router Jig

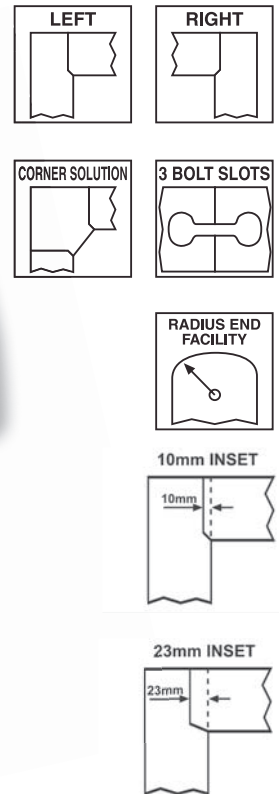
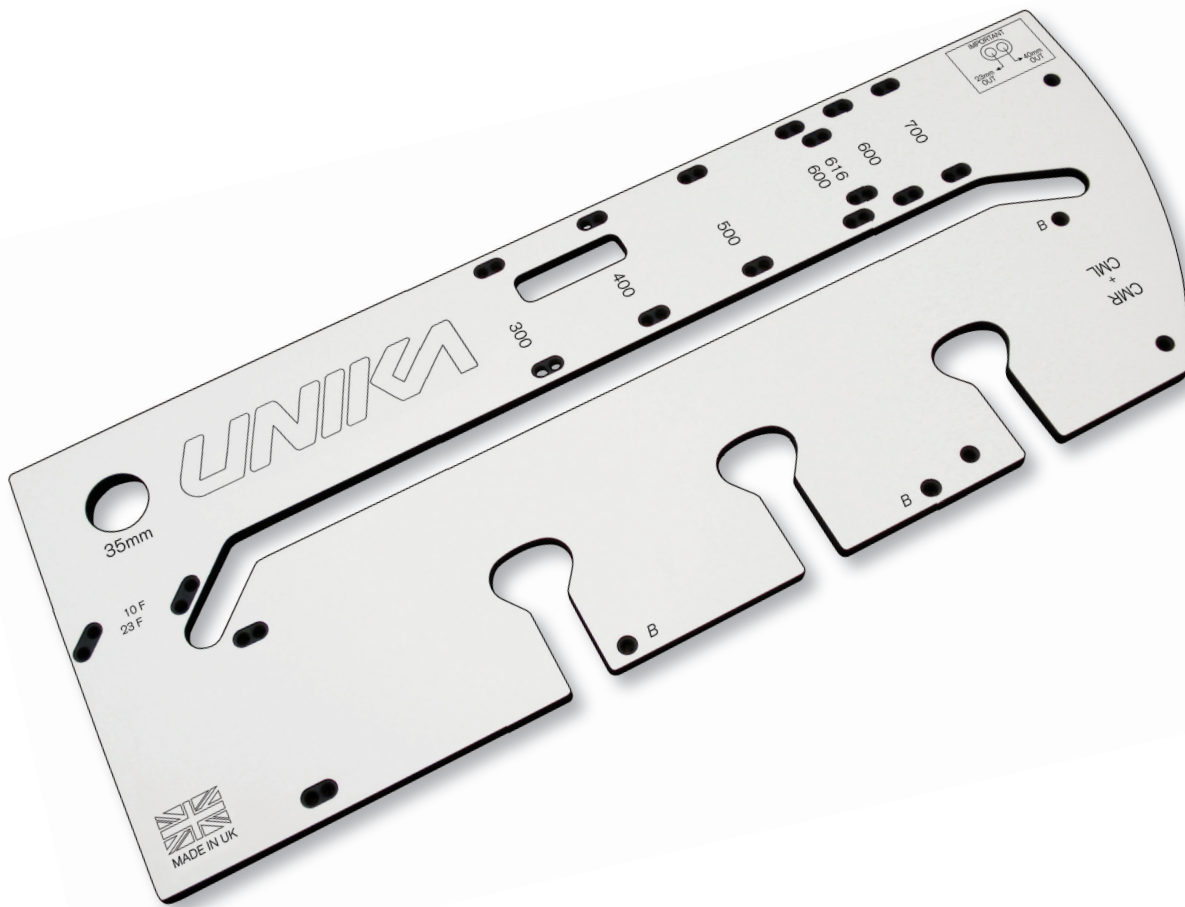

Product Description:

MultiSurface Worktop Router Jig

Key Features:

- Cuts: 300mm, 400mm, 500mm, 600mm, 616mm, 650mm & 700mm worktops.
- Cuts a 10mm and 23mm inset.
 - 10mm inset can be used for:**
 - Composite worktops.
 - Small radius edge laminate worktops (up to 10mm)
 - Solid wood worktops.
 - 23mm inset can be used for:**
 - Laminate worktops with a radius edge of more than 10mm.
- Cuts:
 - 90° left and right joints.
 - Corner cooking solution.

- 3 Bolt Slots.
- Radius end Facility.
- Cuts:
 - 90° left and right joints.
 - Corner cooking solution.

Directions for Use:

Follow instruction manual and choose option for 23mm or 10mm inset

UNIKA COLOR PRODUCTS LTD

Unika House, New York Way, New York Industrial Park, Newcastle upon Tyne, U.K. NE27 0QF

Telephone: +44 (0) 191 259 0033

Fax: +44 (0) 191 257 4525

Email: sales@unika.co.uk www.unika.co.uk



The mark of responsible forestry



PEFC/16-33-1158



ISO 14001 001



OHSAS 18001 001



ISO 9001 001

MultiSurface Worktop Router Jig

Consumer Benefits:

MultiSurface Jig means you only need one jig and it is suitable for use with a variety of worktop materials.

By choosing a 10mm onset for composite and small radius worktops the finished result will be a neater joint that doesn't cut so far into the work surface.

As you usually pay a premium price for composite and small radius worktops the customer will expect a neater finish. This can be achieved by using the new MultiSurface jig.

Product Advantages:

Designed in conjunction with fitters the new MultiSurface jig is engineered to the highest standards.

Machined on the latest CNC machine using diamond cutters for accuracy and a smooth finish.

Made from 12mm hardwearing compact laminate, it is guaranteed never to warp.

Retailer Opportunity:

The new MultiSurface Jig is the first of its kind on the market.

There is no other jig that has been designed to cut both a 10mm and 23mm inset.

For minimum order quantities jigs can be engraved with the companies own name and telephone number.

UNIKA COLOR PRODUCTS LTD

Unika House, New York Way, New York Industrial Park,
Newcastle upon Tyne, U.K. NE27 0QF

Telephone: +44 (0) 191 259 0033

Fax: +44 (0) 191 257 4525

Email: sales@unika.co.uk www.unika.co.uk



The mark of responsible forestry





Instructions

Multi-Surface Worktop Jig

Technical Support Helpline - 0191 2597876

Instruction video available at www.worktopjigs.com

1.01 Jigs are used in quality installation of kitchen, bedroom and bathroom furniture. This jig is manufactured from a composite material to the highest tolerance on CNC machinery to ensure a perfect finish. This material will withstand water, solvents, adhesives and cleaning agents often used in the installation of kitchens. Before starting please take some time to read through these instructions carefully. The jig has been designed to be as easy as possible to use, however we recommend that, if you are inexperienced, you practise on off-cuts prior to the first installation.

This jig has been designed to give a 10mm or a 23mm inset when joining worktops. The 10mm inset gives a better finish when using small radius edged worktops (<6mm) in conventional laminate, composite material or solid timber. The 23mm inset is used when joining worktops with a classic post formed edge. The jig can be used to fit 90° and 45° corners for worktops of widths 300, 400, 500, 600, 616, 650 and 700 mm. By using shims other worktop widths can be accommodated.

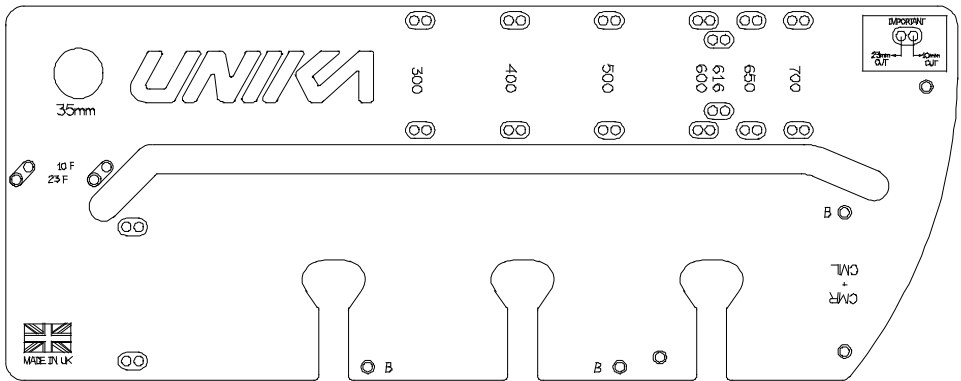

This is what the jig looks like. As you can see many of the holes are in sets of two. This allows you to cut either a 23mm or a 10mm inset into the worktop joint. The 23mm inset has been the standard for many years for worktop with a post formed edge greater than 10mm. Now with the tight radius post formed laminate and composite worktops a smaller inset is possible giving a neater and more professional looking finished joint. This jig will work with most hand routers including De Walt, Bosch and Makita.

The figure below shows the router base set-up required.
Please observe all relevant safety requirements for the use of routers.

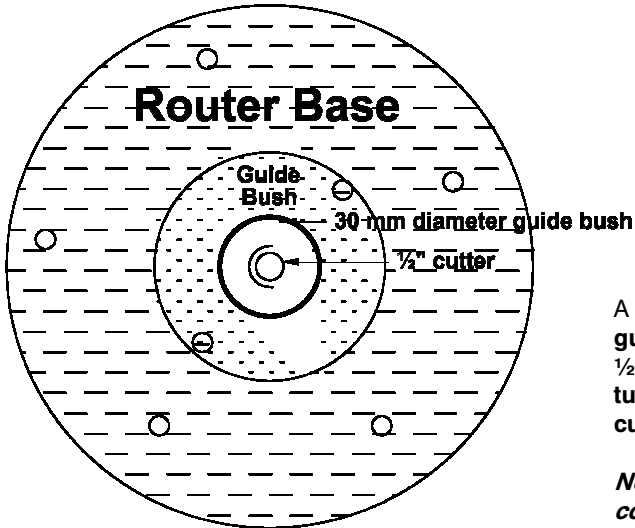

A 30 mm diameter guide bush and a 1/2" (12.7mm) tungsten tipped cutter are required.

No other combination will work satisfactorily.

SAFETY FIRST

1. Make sure all cables are clear of the router.
2. Make sure the work piece is correctly supported.
3. Always use protective goggles when using the router.
4. Do not switch router on with blade touching the work.
5. Never remove the router when it is switched on and moving.

1.02 Conventions and Important Points

It is important that, when cutting, you work the router from left to right. Working from right to left is *with* the cutter's direction. This might cause lack of control resulting in damage to the jig or even injury. Ensure that the guide bush is firmly attached to the router base plate, don't plunge more than 10 mm at a time or use blunt tools.

Make sure the pegs are well seated and are not proud of the surface of the jig.

When working with the centre slot, *always* use the side *nearest* to you *first* for the waste removal, followed by the side *furthest* from you to give the finished edge.

When clamping the jig in position check the pegs are still in contact with the worktop.

Certain types of clamp, if over tightened, can cause the jig to creep out of position.

Ensure the router cutter remains perpendicular when performing all cuts; this is particularly important when performing cuts with the worktop face down.

When making some male cuts you may find it more convenient to remove larger pieces of waste with a jigsaw prior to making the router cuts.

SECTION 2

2.0 90° CORNER

The drawing below shows a typical kitchen lay-out with the terms used in these instructions superimposed.

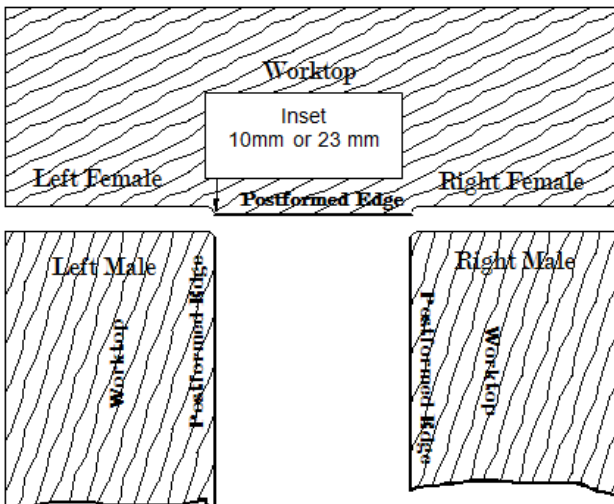

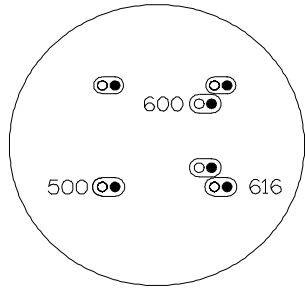
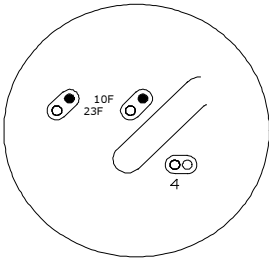

The drawings above show the holes in the left and some on right sides of the jig shown above. The holes coloured black give a 10mm inset the others give 23mm inset when making female cuts. The hole labelled “4” is used when making male cuts when the jig is used with the other face up. This is marked on the other face for 10mm and 23mm inset.

2.1 Female Joints.

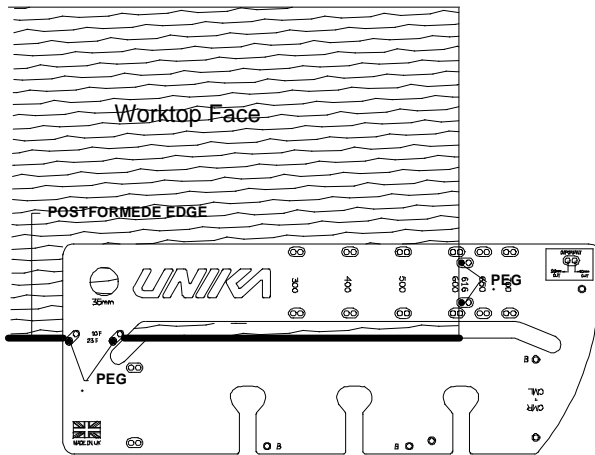

Figure 2. Right Hand Female

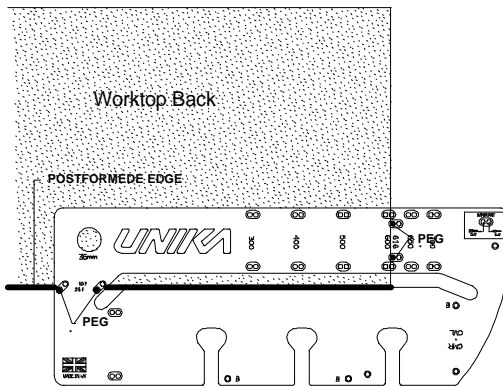

Figure 3. Left- Hand Female

Set the jig on the worktop as shown. Clamp firmly with G-clamps. Position the router in extreme bottom left-hand point of the centre slot. Set the cutting depth to 10 mm. Start the router and pass the router steadily along the centre slot using the side of the slot *nearest* you to guide the router.

Repeat this process increasing the depth of cut by 10 mm for each pass until the post-form edge has been removed.

With the cutter set to maximum depth, use the side of the slot **furthest** from you to guide the router and make one pass to remove approximately 1mm of worktop leaving a perfect cut edge.

Switch off the router at the end of each pass and do not remove the router from the jig until you are sure that the router has stopped. Avoid contact between tool and jig.

2.2 Male Joint

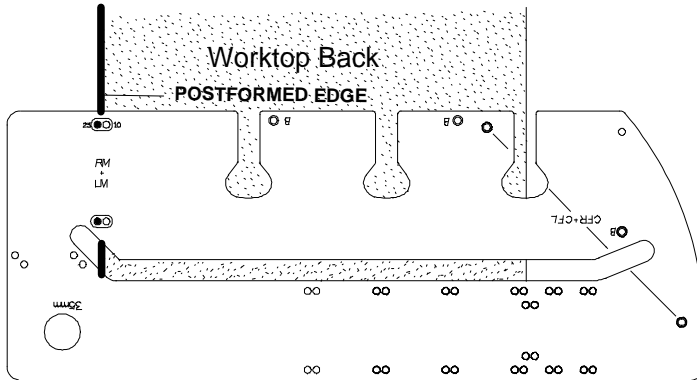

Figure 4. Right-Hand Male Joint

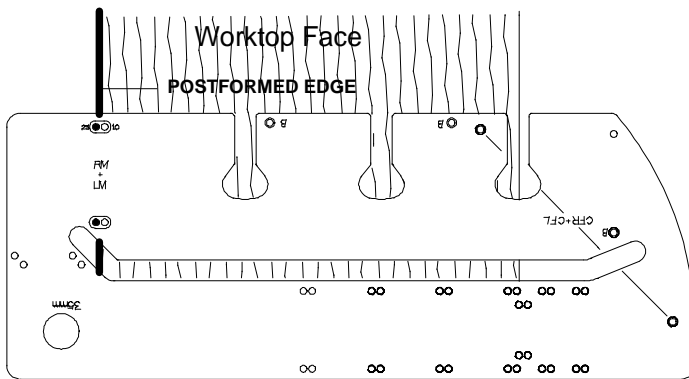

Figure 5. Left-Hand Male Joint

Set the jig on the worktop as shown. Clamp firmly with G-clamps. Position the router in extreme left-hand point of the centre slot and proceed as described above for the female joints.

Note These instructions set up the jig to cut 90° corners. If you wish to allow for slightly out of square walls, remove one or more of the pegs and adjust the angle of the jig against the post-form edge. You should be fully conversant with the usual functions of the jig before attempting this type of adjustment.

2.3 Bolt Slots

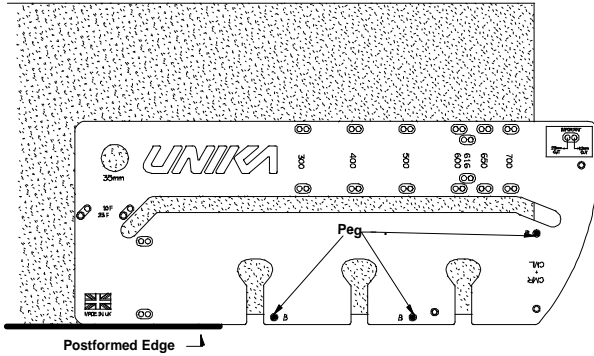

Figure 6. Bolt Slots, Left Hand Female

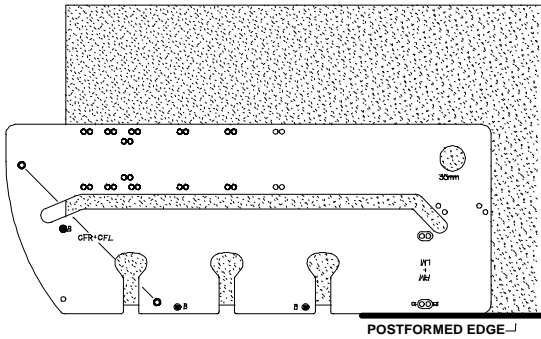

Figure 7. Bolt Slots, Right Hand Female

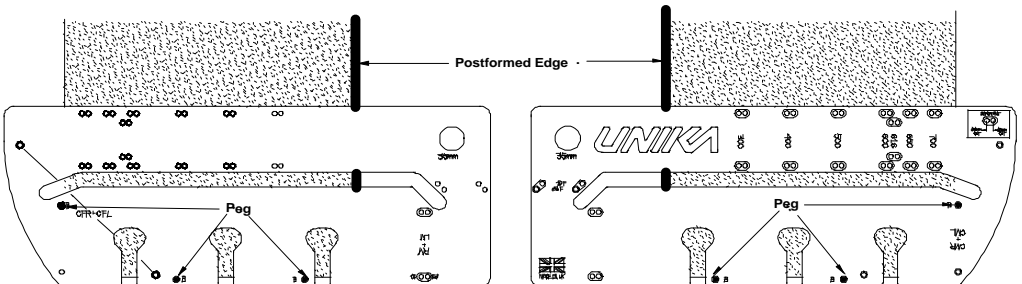

Figure 8. Bolt Slots, Left & Right Hand Male

Place pegs in the holes marked **B** as shown, and then clamp the jig in position with G clamps.

For bolt holes the plunging depth should be set to about 20mm. Ensure this is sufficient to accommodate the joining bolt you are using. Work clockwise around each mushroom shaped slot and remove all the waste. Depending on the worktop width only 2 slots may be needed.

Section 3.0 45° CORNER JOINTS

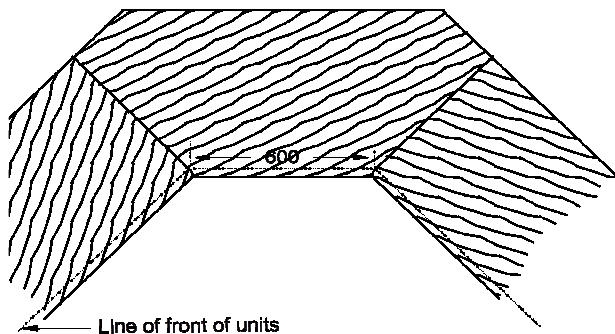

Figure 9. Corner Set-up

The dimensions shown in the drawings below are based on a 600 mm worktop width and will produce corner section suitable for a 600 mm unit. The minimum length of worktop required for a corner section is 1600 mm.

3.01 Female Joints

Place the worktop corner piece face-up and mark a centre line. If using a 600mm deep worktop, mark two lines 640 mm either side of the centre line on the back edge of the worktop. For a 616 mm deep worktop these lines should be 656mm from the centre line and 690 mm for a 650 mm deep worktop.

The jig, used as a straight edge, can help with marking out on this type of corner. With the jig "Date" side down, place pegs in the 2 holes joined by the line marked **CFR+CFL**. Offer the jig up against the post-form edge and align the top edge of the jig with the right-hand 640mm mark. Clamp in position and check again for correct alignment. Cut the 45° corner in a like way to that used for the 90° corner. To finish the corner, offer the male section to the cut edge and mark the position of the back edge on the centre section. Accurately remove with a saw, the "Cut Off" end, as shown is the right hand figure.

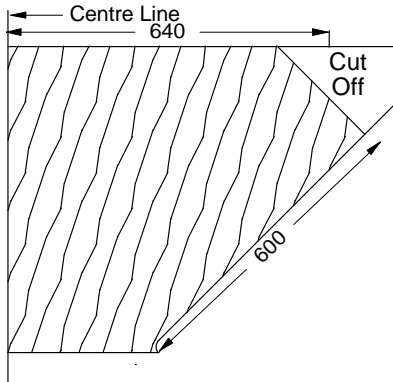

3.02 Male Joints

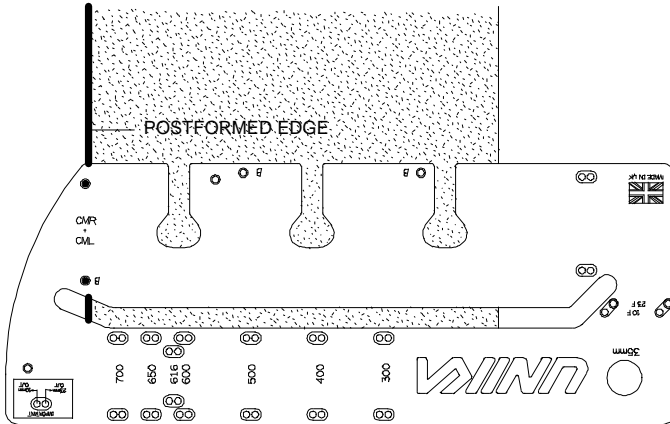

Figure 12. Right Hand 45° Male

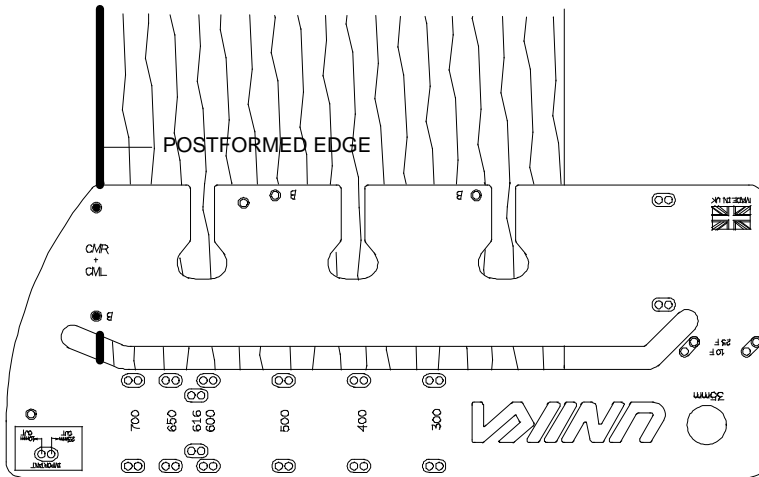

Figure 13. Left Hand 45° Male

Place pegs in the holes "B" and offer them firmly against the post formed edge. Clamp in position and check again to ensure all pegs are in contact with the post formed edge and the jig is in position. Route worktop as described above.

3.03 Bolt Slots

See Figures 7 and 8 above.

3.1 Other U Shape Lay-outs

The "Typical Lay-out" in Figure 1 is the best method of constructing a U shaped layout. There is however other formats which may be used for example the two lay-outs below. These may be necessary depending on worktop length available, location of sink, hob etc.

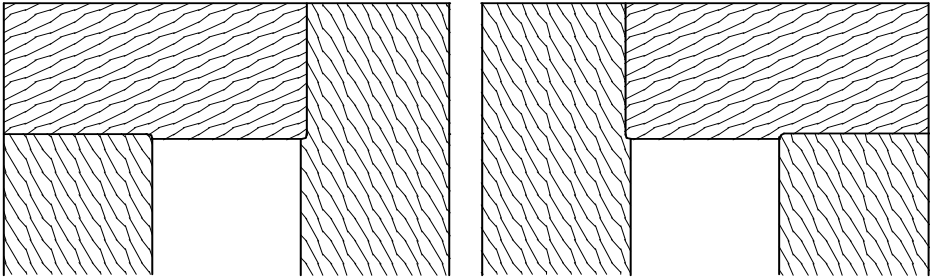

The layouts above are preferable to that below. If however it is necessary to use this construction, careful measurement is required to ensure a good fit.

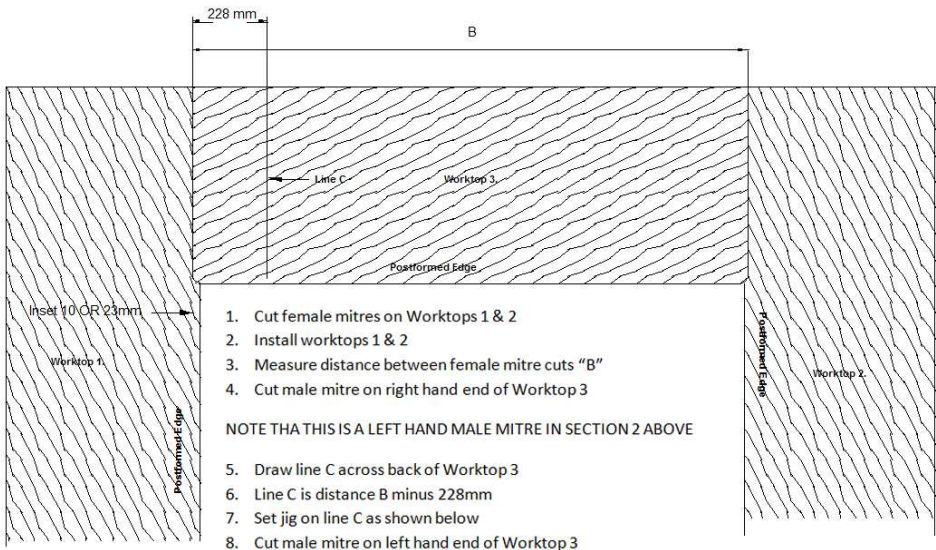

The preferred steps in fitting the setup above are shown as steps 1-8. . Note that the female mitre can be set either 10mm or 23 mm into the worktops. The measurements must be taken from the edge of the cut mitre. The jig set-up to cut the male mitre on the left hand end of Worktop 3 above is shown below.

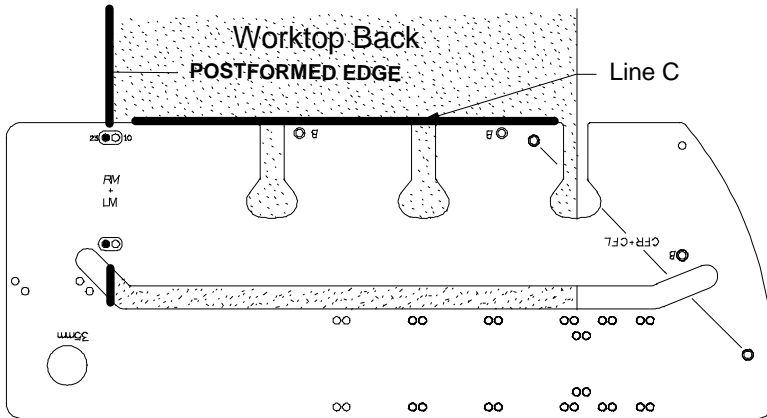

3.2 Breakfast Bar - Radius End

The jig can be used as a guide when adding a radius to the end of a worktop or panel. Use the horizontal array of holes indicated below for the pegs. Place the pegs against the edge of the worktop then, using the radius edge as a guide, mark out radius in pencil and remove the waste with a jigsaw. Set the jig up again, clamp in position and use the router to remove no more than one quarter of the cutter's diameter to leave a perfectly finished edge. *Extreme caution should be exercised when attempting this type of cut - your router can easily tip causing damage or injury.*

COMPLETING THE JOINT

Once the cuts are finished and the worktops trimmed to fit they should be placed on top of the pre levelled cabinets that will support them.

ColorFill should be used in the joint in order to seal the joint and as it is colour matched to the specific worktop it helps to make the joint more inconspicuous.

(See ColorFill tube for instructions on use)

Once the ColorFill has been applied the worktops should be quickly brought together and **Easibolts** tightened into the joining bolt slots from the underside.

Troubleshooting Guide

Problem	Probable Cause	Remedy
Poor finish on male/female joint faces	Incomplete routing process.	Ensure final stroke against <i>far</i> edge of centre slot is performed.
Sharp angle near post-form edge on male/female	Incomplete routing process	Ensure final stroke against <i>far</i> edge is performed.
Good finish but male & female don't match up	Incorrect size of cutter and/or guide bush.	Ensure 12.7mm cutter and 30mm guide bush - <i>nothing else is suitable.</i>
Inconsistent results -wandering edges.	Loose guide bush.	Ensure guide bush is firmly attached to the router base
Irregular gaps on RH male and/or LH female face.	Poor router control	Ensure the cutter remains absolutely perpendicular on these cuts.

Notes and Measurements

Worktop Installation Essentials

Unika ColorFill is the first sealant to be designed specifically for the installation of mitred worktop joints.

ColorFill performs three tasks: It bonds the joint together, it seals the joint against water and domestic detergents and it is exactly colour matched to the worktop so making the finished joint almost invisible.

In addition to joints ColorFill will repair scratches and chips in laminate and melamine surfaces.

Find your ColorFill now at www.colorfill.co.uk



ColorFill Solid Surface Adhesive is a revolutionary two component Methyl Methacrylate which will provide a colour matched seamless look for Solid Surface Worktops.

It can be used on Solid Surface and Composite Worktops made from Acrylic and Acrylic and Polyester blends for example – Corian, HI-MAC'S, Slab Tech, Earthstone, Avonite

EasiBolt will join two mitred worktops together

The EasiBolt holder will keep the bolt in place on the underside of the worktop and leave both hands free for tightening or levelling

EasiBolt is a patented product



TopSeal is a Colour matched Backsplash and Upstand Sealant. High Strength/Waterproof/Flexible It Bonds and Seals at the same time.

TopSeal adheres to all surfaces Granite, Quartz, Laminate, Stainless Steel, Glass and many others.

TopSeal is an excellent gap filler and has little shrinkage. Waterproof and flexible once cured.

10 – 15 minutes open time Excellent bond strength. Use to secure Upstands and Backsplashes in place.

MitrePen is a quick and strong system for joining cornice, pelmet and plinth.

MitrePen is an environmentally friendly, precision marker that prevents the staining caused by overspray.

MitrePen is quick and clean and sets in 10 seconds

Use on: Cornice & Profile Mitre Joints, Melamine end strips, door trims, picture frames, mdf, skirting joints etc.



Gloss Surface Cleaner is a ready to use foam cleaner produces a smear free finish on gloss cupboard doors specially designed to remove dust, light dirt and water marks.

Use on glass, mirrors and chrome surfaces. Cleans and polishes in one easy application.

Professional grade cleaner that will reduce the rate of static pick up on a surface and so reduce the dust build up.

UNIKA COLOR PRODUCTS LTD

Unika House, New York Way, New York Industrial Park,
Newcastle upon Tyne, U.K. NE27 0QF

Telephone: +44 (0) 191 259 0033

Fax: +44 (0) 191 257 4525

Email: sales@unika.co.uk www.unika.co.uk



The mark of responsible forestry



PEFC®



UKAS



UKAS



UKAS

